



# SAILMAN

## FULL BATTEN SYSTEMS

*Technical Innovation and Service - The Fabric of Our Business*

# Introduction & Contents

## Introduction

The principle behind Bainbridge International's Sailman™ system is simple. A range of trackless full batten systems incorporating slides, boxes and battens from one supplier. Bainbridge International has one objective; to provide highly engineered, innovative, effective and good value, fully integrated batten systems to suit most yachts from 22ft to 50ft (6.7 to 15.2 metres).

No other organisation has our knowledge and experience of sailmaking, sail hardware and control systems. This combination of skills is your guarantee of efficiency, quality and reliability.



## Contents

<b>Introduction to Sailman</b>	<b>Page 1</b>
<b>Luff Boxes</b>	<b>Page 2</b>
<b>Full Length Battens</b>	<b>Page 3</b>
<b>Sailman 3000</b>	<b>Pages 4 - 5</b>
<b>Sailman 3500</b>	<b>Pages 6 - 7</b>
<b>Sailman 4000</b>	<b>Pages 8 - 9</b>
<b>Sailman 4000HD</b>	<b>Pages 10 - 11</b>
<b>Batten Specifications</b>	<b>Page 12</b>
<b>Slide Selection Chart</b>	<b>Page 13</b>

## Promotion & Support

We are committed to providing both pre-sale and post-sale support. The Sailman™ booklet provides an easy to understand explanation of the range. Copies are available free to send to your prospective customers.

Every Bainbridge location has a Sailman™ expert on hand to offer you advice, or you can email the team direct on [info@bainbridgeint.co.uk](mailto:info@bainbridgeint.co.uk)

Sailman™ has been designed with simple and low cost maintenance in mind. Spares are readily available from all Bainbridge locations.



# Sailman Full Batten Systems

# sailman

## FULLY INTEGRATED BATTEN SYSTEMS

A range of fully integrated batten systems for boats from 22 to 50 feet (6.7 to 15.2 metres).



- Precision moulded plastic slides
- Solid hinge system with 'lay-flat' rotation
- Flat battens with integral tension adjuster

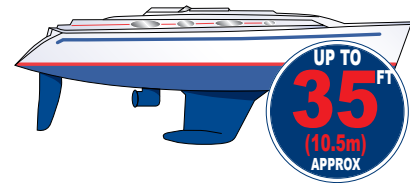

- Ideal for composite spars
- Used with wing masts
- Suits gates that are proud of sail track

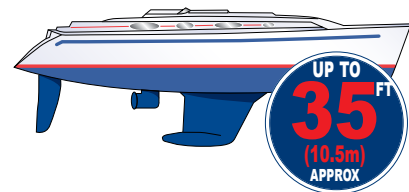

- Low friction sliders with stainless reinforced I-beam
- Cast stainless hinge with 'lay-flat' rotation
- Battens 30mm x 12.7mm or 16mm round

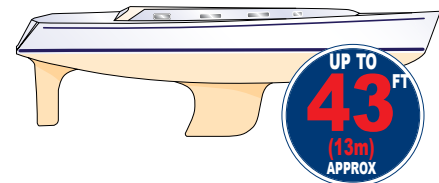

- Low friction sliders with stainless reinforced I-beam
- Cast stainless hinge with 'lay-flat' rotation
- Tough, durable construction
- Battens 30mm x 10.2mm or 12mm round

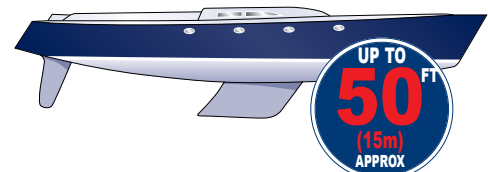

# Sailman Full Batten Systems

## U01540

Series 25 Luff Box:

- Tough injection moulded fibre reinforced construction.
- Integrated tension adjustment system with friction lock.
- Accommodates battens up to 30mm x 5.2mm including 30CT052.
- Top plate design allows simple batten fitting and removal.
- Moulded M10 thread.



## U01531 / U01530

Series 35 Luff Box - U01531 Adjustable / U01530 Non-Adjustable:

- Tough injection moulded fibre reinforced construction.
- Concealed M10 nut for extra strength compared to threaded plastic designs.
- Optional batten tension adjustment with metal drive dog.
- U01530 is non adjustable.
- Snap in guides to suit round or flat battens supplied with every box.



## U01535

Series 35 HD Luff Box - Adjustable:

- Tough injection moulded fibre reinforced construction.
- Concealed M10 nut for extra strength compared to threaded plastic designs.
- Batten tension adjustment for Sailman battens with metal drive dog.
- Snap in guides to suit round or flat battens supplied with every box.



## U01520Y

Series 55 Luff Box - Adjustable:

- Tough injection moulded fibre reinforced construction.
  - Concealed M10 nut for extra strength compared to threaded plastic designs.
  - Tension adjustment for Sailman battens with metal drive dog.
  - Additional cover plates included for both flat battens and rod battens.
  - Tension adjustment options:
    - Adjustable or non adjustable for battens 30CT024, 30CT031/30NT, 30CT044, 30CT052, U30063, U30076, U30102
    - Non adjustable only for battens 06R, 08R, 10R, 12R
- See page 10 for details.



# Sailman Full Batten Systems

Fits with Full Length Batten, Part Number:

30CT024  
30CT031/30NT (US only)  
30CT044  
30CT052

30CT024  
30CT031/30NT (US only)  
30CT044  
30CT052  
U30063  
06R  
08R  
10R

30CT024	U30127
30CT031/30NT (US only)	06R
30CT044	08R
30CT052	10R
U30063	11RD (US only)
U30076	12R (Europe only)
U30102	14R
U30114	16R

30CT024	U30102
30CT031/30NT (US only)	06R
30CT044	08R
30CT052	10R
U30063	11RD (US only)
U30076	12R (Europe only)

Full Length Battens (actual size):

**30CT024**  
  
30mm wide x 2.4mm thick

**30CT031/30NT (US only)**  
  
30mm wide x 3.1mm thick

**30CT044**  
  
30mm wide x 4.4mm thick

**30CT052**  
  
30mm wide x 5.2mm thick

**U30063**  
  
30mm wide x 6.3mm thick

**U30076**  
  
30mm wide x 7.6mm thick

**U30102**  
  
30mm wide x 10.2mm thick

**U30114**  
  
30mm wide x 11.4mm thick

**U30127**  
  
30mm wide x 12.7mm thick

**06R**  
  
6mm

**08R**  
  
8mm

**10R**  
  
10mm

**11RD (US only)**  
  
12mm

**12R (Europe only)**  
  
12mm

**14R**  
  
14mm

**16R**  
  
16mm



# Sailman 3000

For boats up to 35 feet (10.5m) approx.

## Sailman 3000 FULL BATTEN SYSTEM

Sailman 3000 is a compact integrated full batten system for boats up to 35ft. The system comprises seven profiles of slide and a durable slide linkage that is compatible with Series 25 and Series 35 batten boxes.

Sailman 3000 is compatible with most modern internal mast tracks and despite being designed to be affordable, still includes many detailed design features and advanced quality materials.

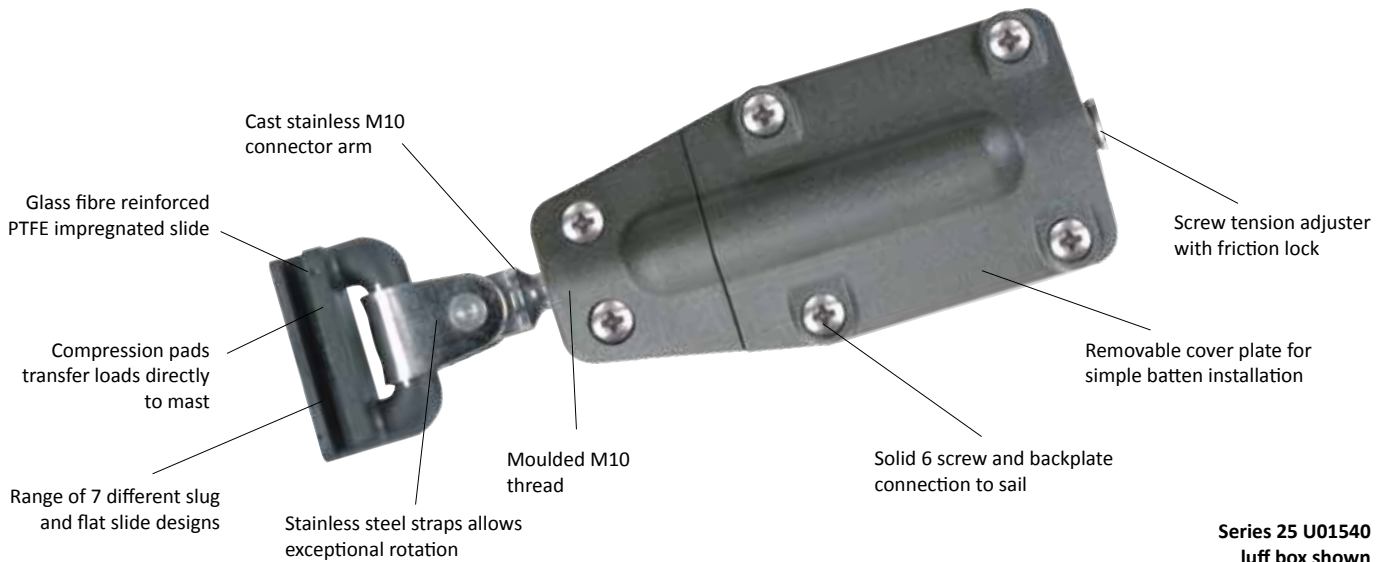

**U99980 Selden Groove Insert**



### Sail Areas

Recommended maximum sail areas according to yacht type and roach variation:

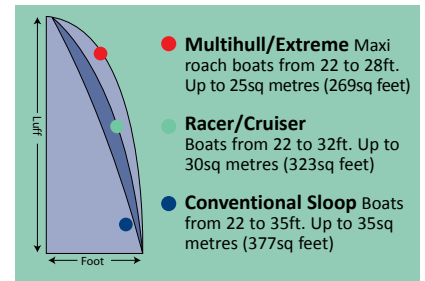

The big-roached rigs of some multihulls and water-ballasted yachts add considerably to the loads applied to batten systems. If in doubt contact Bainbridge International for further advice.

For boats up to 35 feet (10.5m) approx.

Please note: Images are for illustration purposes only and are not actual size.

**A107**  
Low friction slide  
15.2mm width

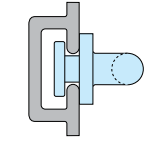

**A108**  
Low friction slide  
19mm width

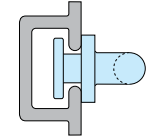

**A109**  
Low friction slide  
22.2mm width

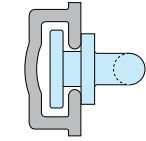

**A114**  
Low friction slide  
15.2mm Selden  
'E' Series  
15.2mm wide

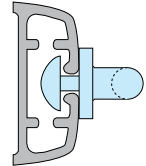

**A116**  
Low friction slide  
7.4mm diameter

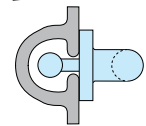

**A117**  
Low friction slide  
8.4mm diameter

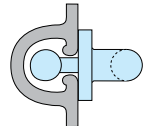

**A118**  
Low friction slide  
11.4mm diameter

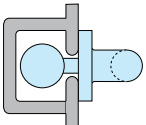

Slides should be a snug fit and bear on aft face of mast.



**1 Batten Slide**



**2 M10 Slide Linkage U00642**



**3 Long reach screw-on shackle A035BK**



**1 Batten Slides:**

- Seven profiles to fit most modern spars.
- Precision moulded from glass fibre reinforced plastic with a PTFE impregnation.
- Integral compression pad transfers load directly on to aft face of spar.
- Slides can also be used as intermediates using A035BK long reach shackle.
- All slides measure 45mm or 1 3/4 inches in length.

**2 M10 Slide Linkage U00642:**

- Pressure formed 316 stainless steel double toggle transfers compression directly and evenly onto slide.
- M10 thread allows connection to Series 25, Series 35 and most other brands of batten box.
- Hinge system allows 'lay-flat' rotation of battens when sail is stowed or reefed.
- Clevis pin with heavy duty splitting ring provides simple sail removal.

**3 Long Reach Screw-On Shackle A035BK:**

- Specifically designed for connecting our regular 7 Allslip slides to full batten sails, including those equipped with Sailman 3000, 3500 and 4000 systems.

**Series 25 Luff Box U01540**



**Series 35 Luff Box U01531 / U01530**



**Series 35 Heavy Duty Luff Box Adjustable U01535**

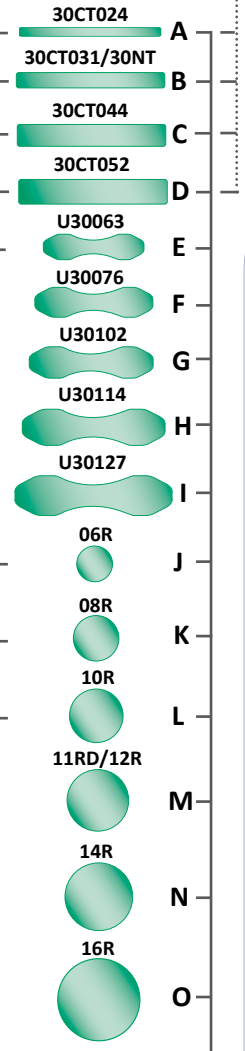

Part No.	Description	Width: mm/in	Waist: mm/in	Length: mm/in	Connection	Weight: gm /oz	Battens
<b>Slides</b>							
A107	Low Friction Slide 16mm Flat	15.2 5/8	7.5 1/4	45.0 1 3/4	U00642/A035BK/Webbing	13 0.5	-
A108	Low Friction Slide 19mm Flat	19.0 3/4	9.0 3/8	45.0 1 3/4	U00642/A035BK/Webbing	14 0.5	-
A109	Low Friction Slide 22mm Flat	22.2 7/8	11.0 7/16	45.0 1 3/4	U00642/A035BK/Webbing	16 0.6	-
A114	Low Friction Slide 16mm Selden 'E' Series	15.2 5/8	4.4 3/16	45.0 1 3/4	U00642/A035BK/Webbing	14 0.5	-
A116	Low Friction Slide 8mm Diameter	7.4 5/16	4.0 5/32	45.0 1 3/4	U00642/A035BK/Webbing	12 0.4	-
A117	Low Friction Slide 9mm Diameter	8.4 3/8	4.0 5/32	45.0 1 3/4	U00642/A035BK/Webbing	13 0.5	-
A118	Low Friction Slide 12.5mm Diameter	11.4 1/2	4.0 5/32	45.0 1 3/4	U00642/A035BK/Webbing	15 0.5	-
<b>Connectors</b>							
A035BK	Long Reach Screw-On Shackle	-	-	61 2 7/16	-	-	-
U00642	Slide Linkage M10	-	-	-	M10 Thread	50 1.7	-
U99980	Selden Sail Groove Insert	30 1 3/16	-	155 6 1/4	-	-	-
<b>Luff Boxes</b>							
U01530	Series 35 Standard Luff Box	62 2 7/16	-	120 4 1/4	M10 Thread	209 7.4	A, B, C, D, E, J, K, L
U01531	Series 35 Luff Box With Batten Tension Adjuster	62 2 7/16	-	120 4 3/4	M10 Thread	234 8.3	A, B, C, D, E, J, K, L
U01535	Series 35 HD Luff Box With Batten Tension Adjuster	62 2 7/16	-	120 4 3/4	M10 Thread	267 9.4	All Battens
U01540	Series 25 Standard Luff Box With Batten Tension Adjuster	50 2	-	104 4 1/4	M10 Thread	122 4.3	A, B, C, D

# Sailman 3500

For boats up to 35 feet (10.5m) approx.

## Sailman 3500 FULL BATTEN SYSTEM

The Sailman 3500 system has been specifically designed to fit a full batten sail on three of the most difficult types of spars:

- Alloy spars with sail feeding gates that are proud of the aft face of the mast.
- Composite spars.
- Alloy and composite wing masts.

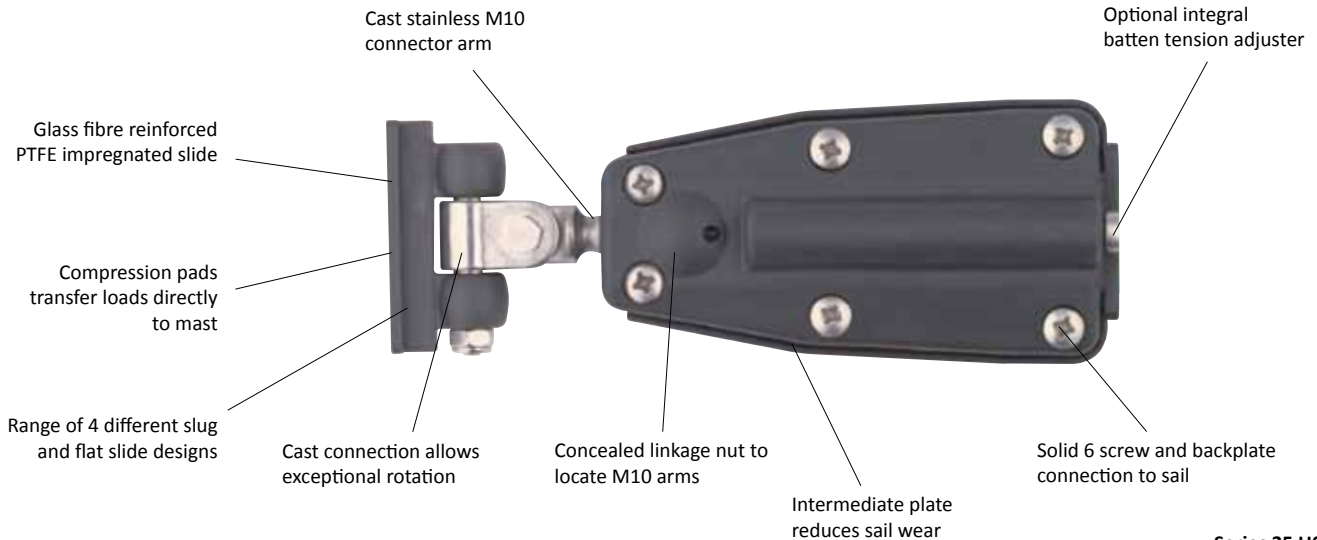

Series 35 U01531  
luff box shown



### Sail Areas

Recommended maximum sail areas according to yacht type and roach variation:

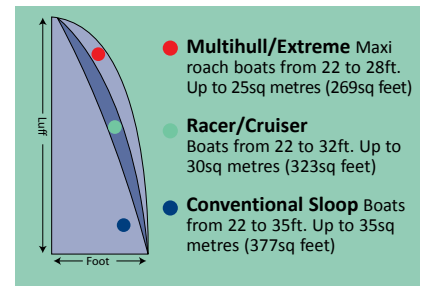

The big-roached rigs of some multihulls and water-ballasted yachts add considerably to the loads applied to batten systems. If in doubt contact Bainbridge International for further advice.



For boats up to 35 feet (10.5m) approx.

U00341S M10 Arm  
U00361 Intermediate



15.5mm width  
7.3mm waist

U00343S M10 Arm  
U00363 Intermediate



17.9mm width  
8.7mm waist

U00345S M10 Arm  
U00365 Intermediate



21.5mm width  
10.3mm waist

U00357S M10 Arm  
U00377 Intermediate



9.0mm width  
3.4mm waist

Please note: Images are for illustration purposes only and are not actual size.

1 Intermediate Slide



1 M10 Batten Slide

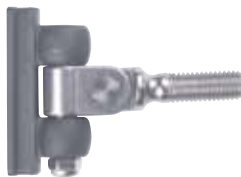

Series 25 Luff Box  
U01540



Series 35 Luff Box  
U01531 / U01530



Series 35 Heavy Duty  
Luff Box  
Adjustable U01535

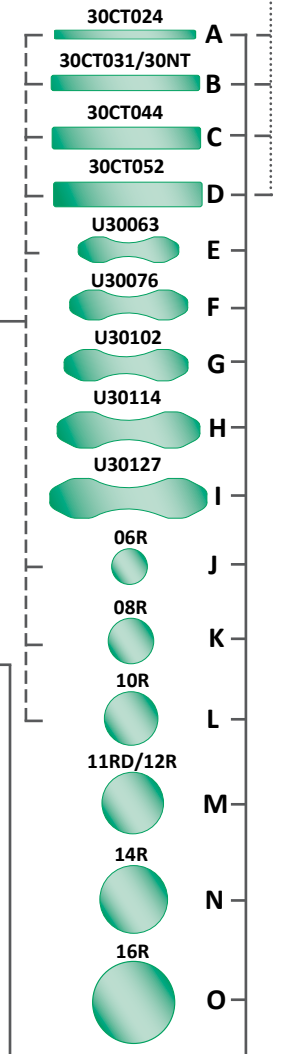

1 Batten Slides:

- Sailman 3500 slides are designed to run inside the mast groove and unlike Sailman 3000 and 4000 slides, do not bear on the aft face of the mast. This allows them to run past feeding gates and to slide in very narrow grooves on composite wing masts.
- To prevent wear on composite spars the slides have no exposed metal parts.
- The smallest slug version has a waist of just 3.4mm, allowing it to fit the narrowest of grooves.
- Glass reinforced and PTFE impregnated construction.
- Fully articulating solid stainless steel joint allows 'lay-flat' rotation of battens when sail is stowed or reefed.
- M10 thread allows connection to Series 25, Series 35, Series 55 and most other brands of batten box.
- Cotton reel on intermediate slides for easy sail removal and to reduce wear.

Part No.	Description	Width: mm/in	Waist: mm/in	Length: mm/in	Connection	Weight: gm /oz	Battens
<b>Intermediate Slides</b>							
U00361	Intermediate/Head Slide 15.5mm	15.5	5/8 7.3	7/64 55.0	2 1/16 55.0	30 1.0	-
U00363	Intermediate/Head Slide 18mm	17.9	5/8 8.7	9/64 55.0	2 1/16 55.0	31 1.1	-
U00365	Intermediate/Head Slide 22mm	21.5	7/8 10.3	5/32 55.0	2 1/16 55.0	34 1.2	-
U00377	Intermediate/Head Slide 9mm Diameter	9.0	1/8 3.4	1/8 55.0	2 1/16 55.0	30 1.0	-
<b>Batten Slides</b>							
U00341S	Batten Slide 15.5mm Series 35 Luff Box	15.5	5/8 7.3	7/64 55.0	2 1/16 55.0	81 2.9	-
U00343S	Batten Slide 18mm Series 35 Luff Box	17.9	3/4 8.7	9/64 55.0	2 1/16 55.0	81 2.9	-
U00345S	Batten Slide 22mm Series 35 Luff Box	21.5	7/8 10.3	5/32 55.0	2 1/16 55.0	84 3.0	-
U00357S	Batten Slide 9mm Diameter Series 35 Luff Box	9.0	1/8 3.4	1/8 -	- -	80 2.8	-
<b>Luff Boxes</b>							
U01530	Series 35 Standard Luff Box	62	2 7/16 -	- - 120	4 1/4 120	209 7.4	A, B, C, D, E, J, K, L
U01531	Series 35 Luff Box With Batten Tension Adjuster	62	2 7/16 -	- - 120	4 3/4 120	234 8.3	A, B, C, D, E, J, K, L
U01535	Series 35 HD Luff Box With Batten Tension Adjuster	62	2 7/16 -	- - 120	4 3/4 120	267 9.4	All Battens
U01540	Series 25 Standard Luff Box With Batten Tension Adjuster	50	2 -	- - 104	4 1/4 104	122 4.3	A, B, C, D

# Sailman 4000

For boats up to 43 feet (13m) approx.

## Sailman 4000 FULL BATTEN SYSTEM

Sailman 4000 is a premium trackless full batten system for boats up to 43ft. The system comprises seven profiles of slides that feature a durable hinge system and stainless steel reinforced slugs. All slides are compatible with Series 35 and Series 55 batten boxes.

Sailman 4000 has been designed as a premium system that, through careful design and detailed engineering, delivers excellent performance and strength without the complication and cost of fitting an external track.

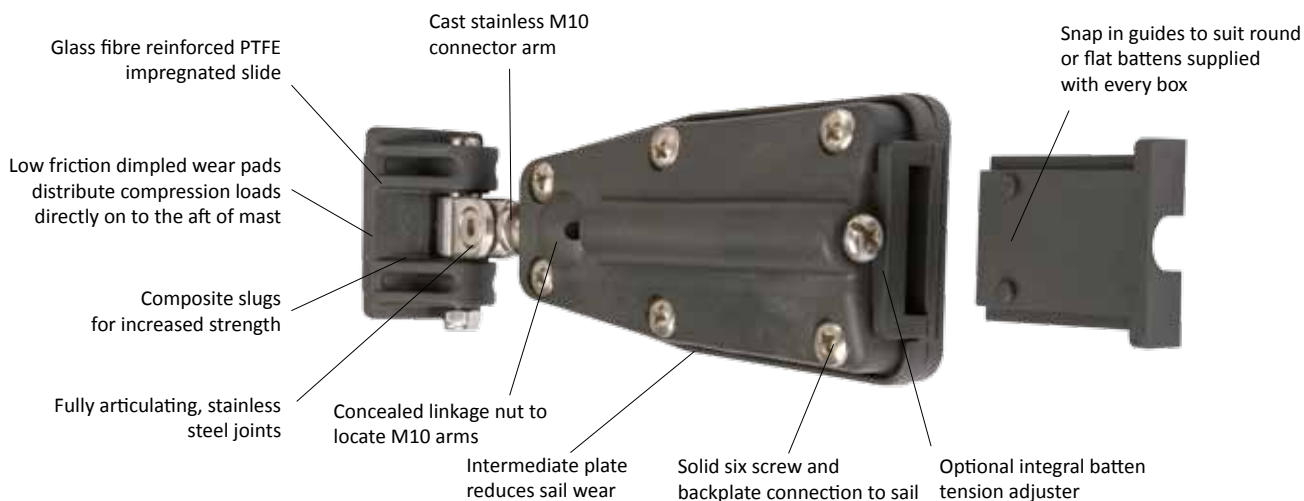

Series 35 U01531  
luff box shown

### Head Slides

Part No.	Description	Width: mm/in	Waist: mm/in	Length: mm/in	Weight: gm /oz
U00462H	Heavy Duty Head Slide 16mm Flat	16.3 5/8	8.5 9/64	114 4 1/2	225 7.9
U00463H	Heavy Duty Head Slide Selden 'C'	19.8 3/4	9.4 3/8	114 4 1/2	235 8.3
U00464H	Heavy Duty Head Slide 19mm Flat	18.8 3/4	4.7 3/16	114 4 1/2	235 8.3
U00466H	Heavy Duty Head Slide 23mm Flat	23 7/8	12 1/2	114 4 1/2	235 8.3
U00468H	Heavy Duty Head Slide 24mm Flat	24 7/8	12 1/2	114 4 1/2	225 7.9
U00472H	Heavy Duty Head Slide 10mm Slug	10 3/8	3.6 1/8	114 4 1/2	227 8.0
U00474H	Heavy Duty Head Slide 11mm Slug	11 7/16	3.7 1/8	114 4 1/2	225 7.9
B942ABK	Sailman Headboard	116 4 1/2	-	142 6 7/8	85 2.9

- A pressed stainless steel hinge unit links two slides together for extra strength.
- The B942ABK Headboard can also be fitted.



### Sail Areas

Recommended maximum sail areas according to yacht type and roach variation:

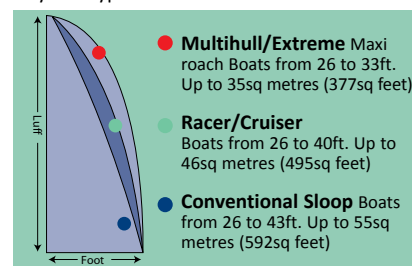

The big-roached rigs of some multihulls and water-ballasted yachts add considerably to the loads applied to batten systems. If in doubt contact Bainbridge International for further advice.

For boats up to 43 feet (13m) approx.

Please note: Images are for illustration purposes only and are not actual size.

U00462 Intermediate  
U00442S M10  
U00462H 16.3mm headslide

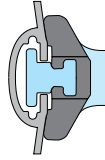

U00468 Intermediate  
U00448S M10  
U00468H 24mm headslide



U00464 Intermediate  
U00444S M10  
U00464H 18.8mm headslide



U00472 Intermediate  
U00452S M10  
U00472H 10mm headslide

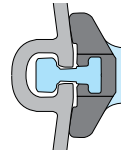

U00466 Intermediate  
U00446S M10  
U00466H 23mm headslide

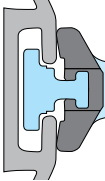

U00474 Intermediate  
U00454S M10  
U00474H 11mm headslide



U00463 Intermediate  
U00443S M10  
U00463H 19.8mm headslide

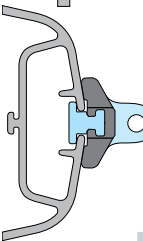

Slides should be a snug fit and bear on aft face of mast.



Series 35 Luff Box  
U01531 / U01530



Series 35 Heavy Duty  
Luff Box  
Adjustable U01535



Series 55 Luff Box  
U01520Y



### 1 M10 Batten Slide



### 2 Intermediate Slide



### 1 Batten Slides:

- Seven profiles to fit most modern spars.
- Precision moulded from glass fibre reinforced plastic with PTFE impregnation.
- Durable stainless steel hinge system and connecting arm.
- Low friction compression pads transfer load directly onto aft face of spar.
- Composite slugs for extra strength.

### 2 Intermediate Slide:

- Moulded cotton reels for web on attachment in intermediate positions.
- Can also be webbed to standard headboards as light duty headslides.

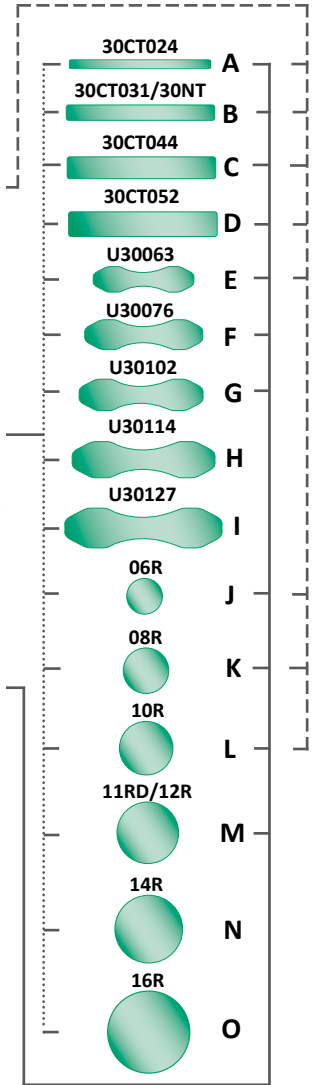

The Sailman 4000 car is 52mm overall in length with a 40mm slug which is reinforced with a full width stainless steel I-beam insert giving it the strength to deal with the application.

Part No.	Description	Width: mm/in	Waist: mm/in	Length: mm/in	Connection	Weight: gm /oz	Battens				
<b>Intermediate Slides</b>											
U00462	Intermediate/Head Slide 16mm Flat	16.3	$\frac{5}{8}$	8.5	$\frac{3}{64}$	52	$2\frac{1}{16}$	Webbing	61	2.2	-
U00463	Intermediate/Head Slide Selden 'C'	19.8	$\frac{3}{4}$	9.4	$\frac{3}{8}$	52	$2\frac{1}{16}$	Webbing	68	2.4	-
U00464	Intermediate/Head Slide 19mm Flat	18.8	$\frac{3}{4}$	4.7	$\frac{3}{16}$	52	$2\frac{1}{16}$	Webbing	65	2.3	-
U00466	Intermediate/Head Slide 23mm Flat	23	$\frac{7}{8}$	12	$\frac{1}{2}$	52	$2\frac{1}{16}$	Webbing	68	2.4	-
U00468	Intermediate/Head Slide 24mm Flat	24	$\frac{15}{16}$	12	$\frac{1}{2}$	52	$2\frac{1}{16}$	Webbing	68	2.4	-
U00472	Intermediate/Head Slide 10mm Slug	10	$\frac{3}{8}$	3.6	$\frac{1}{8}$	52	$2\frac{1}{16}$	Webbing	64	2.3	-
U00474	Intermediate/Head Slide 11mm Slug	11	$\frac{7}{16}$	3.7	$\frac{1}{8}$	52	$2\frac{1}{16}$	Webbing	63	2.2	-
U00322	Spare Cotton Reel for Intermediate Slides	-	-	-	-	-	-	Webbing	-	-	-
<b>Batten Slides</b>											
U00442S	Batten Slide 16mm Flat	16.3	$\frac{5}{8}$	8.5	$\frac{3}{64}$	52	$2\frac{1}{16}$	M10 Thread	112	4.0	-
U00443S	Batten Slide Selden 'C'	19.8	$\frac{3}{4}$	9.4	$\frac{3}{8}$	52	$2\frac{1}{16}$	M10 Thread	118	4.2	-
U00444S	Batten Slide 19mm Flat	18.8	$\frac{3}{4}$	4.7	$\frac{3}{16}$	52	$2\frac{1}{16}$	M10 Thread	112	4.0	-
U00446S	Batten Slide 23mm Flat	23	$\frac{7}{8}$	12	$\frac{1}{2}$	52	$2\frac{1}{16}$	M10 Thread	118	4.2	-
U00448S	Batten Slide 24mm Flat	24	$\frac{15}{16}$	12	$\frac{1}{2}$	52	$2\frac{1}{16}$	M10 Thread	117	4.1	-
U00452S	Batten Slide 10mm Slug	10	$\frac{3}{8}$	3.6	$\frac{1}{8}$	52	$2\frac{1}{16}$	M10 Thread	113	4.0	-
U00454S	Batten Slide 11mm Slug	11	$\frac{7}{16}$	3.7	$\frac{1}{8}$	52	$2\frac{1}{16}$	M10 Thread	112	4.0	-
<b>Luff Boxes</b>											
U01530	Series 35 Standard Luff Box	62	$2\frac{7}{16}$	-	-	120	$4\frac{1}{4}$	M10 Thread	209	7.4	A, B, C, D, E, J, K, L
U01531	Series 35 Luff Box With Batten Tension Adjuster	62	$2\frac{7}{16}$	-	-	120	$4\frac{3}{4}$	M10 Thread	234	8.3	A, B, C, D, E, J, K, L
U01535	Series 35 HD Luff Box With Batten Tension Adjuster	62	$2\frac{7}{16}$	-	-	120	$4\frac{3}{4}$	M10 Thread	267	9.4	All Battens
U01520Y	Series 55 Luff Box With Batten Tension Adjuster	73	$2\frac{7}{8}$	-	-	127	5	M10 Thread	275	9.7	A, B, C, D, E, F, G, J, K, L, M
U99980	Selden/Kemp Sail Groove Insert	30	$1\frac{3}{16}$	-	-	155	$6\frac{1}{4}$	-	-	-	-

# Sailman 4000HD

For boats from 30 (9m) to 50 feet (15m) approx.

## Sailman 4000HD

New Sailman 4000HD provides a super strong step up from the standard 4000 system, allowing a simple in mast solution for yachts up to 50 feet, which can be retro-fitted to many modern mast profiles. The fact that it is an in mast system makes it an obvious choice to save time and money when compared to costly and difficult to fit track systems.

### FULL BATTEN SYSTEM

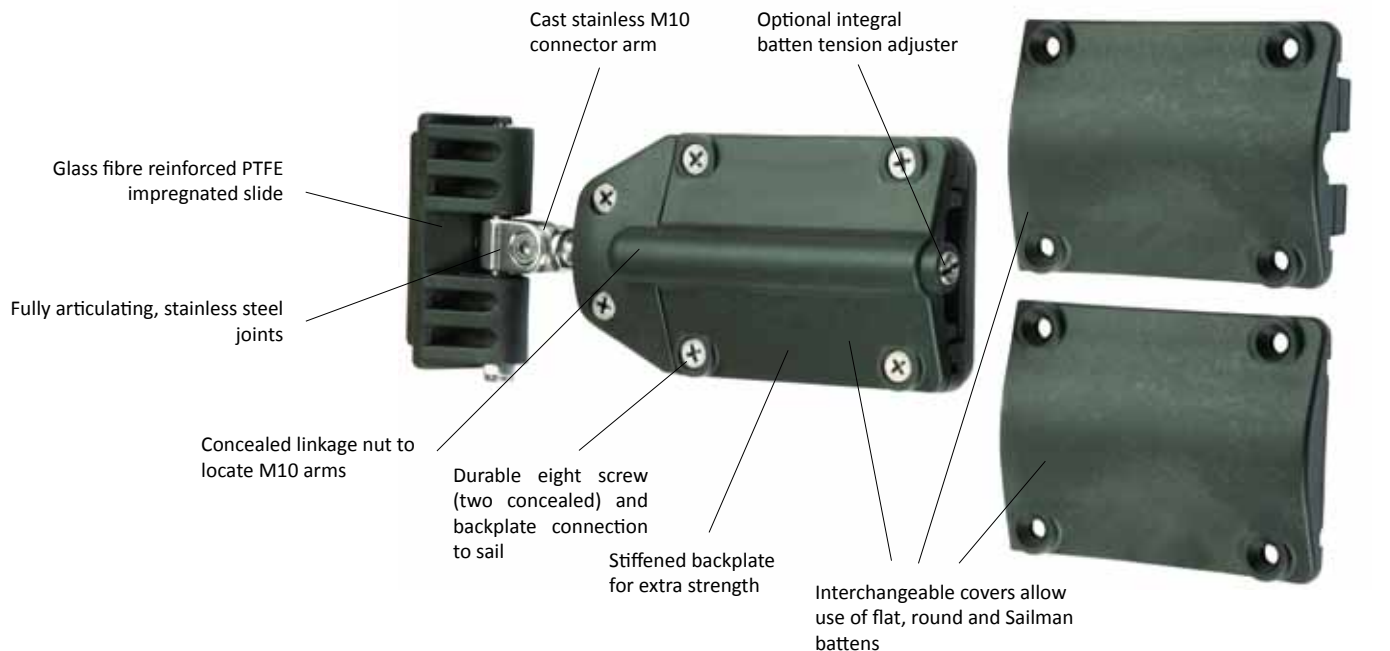

Series 55 U01520Y luff box, which includes 2 additional covers, shown



#### Sail Areas

Recommended maximum sail areas according to yacht type and roach variation:

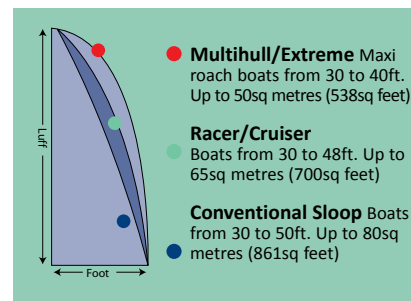

The big-roached rigs of some multihulls and water-ballasted yachts add considerably to the loads applied to batten systems. If in doubt contact Bainbridge International for further advice.

# Sailman 4000HD

For boats from 30 feet (9m) to 50 feet (15m) approx.

Slides should be a snug fit and bear on aft face of mast.



Please note: Images are for illustration purposes only and are not actual size.

## 1 M10 Batten Slides:

- Moulded cotton reels available (U00322) for web on attachment in intermediate positions.
- Can also be webbed to standard headboards as headslides.
- Precision moulded from glass fibre reinforced plastic with PTFE impregnation.
- Durable stainless steel hinge system and connecting arm.
- Low friction compression pads transfer load directly on to aft face of spar.
- All slugs feature stainless steel 'I' beam inserts for extra strength.
- U00466 and U00474 from the Sailman 4000 range can be used as intermediate slides.

The Sailman 4000HD car is 80mm overall in length with a 68mm slug which is reinforced with a full width stainless steel I-beam insert giving it the strength to deal with the application. The new HD car is completely compatible with the existing Sailman 4000 system utilising the same proven M10 connections.

U00446SHD

Part No.	Description	Width: mm/in	Waist: mm/in	Length: mm/in	Connection	Weight: gm /oz	Battens
<b>Batten Slides</b>							
U00446SHD	Batten Slide 23mm Flat	23	$\frac{7}{8}$	12	$\frac{1}{2}$	80	$3 \frac{1}{8}$ M10 Thread 160 5.6 -
U00454SHD	Batten Slide 11mm Slug	11	$\frac{7}{16}$	3.7	$\frac{1}{8}$	80	$3 \frac{1}{8}$ M10 Thread 158 5.6 -
<b>Luff Boxes</b>							
U01530	Series 35 Standard Luff Box	62	$2 \frac{7}{16}$	-	-	120	$4 \frac{1}{4}$ M10 Thread 209 7.4 A, B, C, D, E, J, K, L
U01531	Series 35 Luff Box With Batten Tension Adjuster	62	$2 \frac{7}{16}$	-	-	120	$4 \frac{3}{4}$ M10 Thread 234 8.3 A, B, C, D, E, J, K, L
U01535	Series 35 HDLuff Box With Batten Tension Adjuster	62	$2 \frac{7}{16}$	-	-	120	$4 \frac{3}{4}$ M10 Thread 267 9.4 All Battens
U01520Y	Series 55 Luff Box With Batten Tension Adjuster	73	$2 \frac{7}{8}$	-	-	127	5 M10 Thread 275 9.7 A, B, C, D, E, F, G, J, K, L, M
U099980	Selden/Kemp Sail Groove Insert	30	$1 \frac{3}{16}$	-	-	155	$6 \frac{1}{4}$ - - -
U00322	Spare Cotton Reel for Intermediate Slides	-	-	-	-	-	Webbing - - -



# Full Length Battens

## Flat Battens

These low cost, quality pultrusions are tough and durable. The use of battens can help minimise sail wear. All styles are 30mm wide but vary in thickness to offer logical and progressive increases in stiffness. This allows different stiffness' to use the same width pocket and luff box.



## Flat Battens - Specifications

Part No.	Luff Box	Profile	Width	Thickness	Stiffness	Weight	Length
30CT024	U01540 U01531/30 U01535 U01520Y	Flat	30mm 1 <sup>3</sup> / <sub>16</sub> "	2.4mm <sup>3</sup> / <sub>31</sub> "	0.5kgm	145gms/m 1.6oz/ft	6m 19.7ft
30CT031 / 30NT (US only)	U01540 U01531/30 U01535 U01520Y	Flat	30mm 1 <sup>3</sup> / <sub>16</sub> "	3.1mm <sup>1</sup> / <sub>8</sub> "	1kgm	188gms/m 2.0oz/ft	6m 19.7ft
30CT044	U01540 U01531/30 U01535 U01520Y	Flat	30mm 1 <sup>3</sup> / <sub>16</sub> "	4.4mm <sup>5</sup> / <sub>32</sub> "	3kgms	266gms/m 2.9oz/ft	6m 19.7ft
30CT052	U01540 U01531/30 U01535 U01520Y	Flat	30mm 1 <sup>3</sup> / <sub>16</sub> "	5.2mm <sup>7</sup> / <sub>32</sub> "	5kgms	315gms/m 3.4oz/ft	6m 19.7ft

## Sailman Battens

Highest quality vinylester pultrusions deliver ultimate tenacity for demanding full batten applications. Selected for the BT Global Challenge, the world's toughest yacht race, they feature a logical and progressive range of stiffness' and a common 30mm width.



## Sailman Battens - Specifications

Part No.	Luff Box	Profile	Width	Thickness	Stiffness	Weight	Length
U30063	U01531/30 U01535 U01520Y	Sailman	30mm 1 <sup>3</sup> / <sub>16</sub> "	6.3mm <sup>1</sup> / <sub>4</sub> "	7kgms	293gms/m 3.2oz/ft	12m 39.4ft
U30076	U01535 U01520Y	Sailman	30mm 1 <sup>3</sup> / <sub>16</sub> "	7.6mm <sup>5</sup> / <sub>16</sub> "	15kgms	382gms/m 4.1oz/ft	12m 39.4ft
U30102	U01535 U01520Y	Sailman	30mm 1 <sup>3</sup> / <sub>16</sub> "	10.2mm <sup>13</sup> / <sub>32</sub> "	37kgms	530gms/m 5.7oz/ft	12m 39.4ft
U30114	U01535	Sailman	30mm 1 <sup>3</sup> / <sub>16</sub> "	11.4mm <sup>7</sup> / <sub>16</sub> "	58kgms	618gms/m 6.4oz/ft	12m 39.4ft
U30127	U01535	Sailman	30mm 1 <sup>3</sup> / <sub>16</sub> "	12.7mm <sup>1</sup> / <sub>2</sub> "	94kgms	704gms/m 7.6oz/ft	12m 39.4ft

## Round Battens

Outstanding stiffness to weight combined with low cost make round section pultrusions an excellent choice for full batten applications, although they are most liable to breakage and can cause sail chafe.

- Longer lengths are available against special order. Long packages may however involve the purchase in higher than normal freight costs.



## Round Battens - Specifications

Part No.	Luff Box	Profile	Width	Thickness	Stiffness	Weight	Length
06R	U01531/30 U01535 U01520Y	Rod	-	6mm <sup>1</sup> / <sub>4</sub> "	1kgm	52gms/m 0.7oz/ft	5m (Europe) 20ft (US)
08R	U01531/30 U01535 U01520Y	Rod	-	8mm <sup>5</sup> / <sub>16</sub> "	3.5kgms	88gms/m 1.0oz/ft	5m (Europe) 20ft (US)
10R	U01531/30 U01535 U01520Y	Rod	-	10mm <sup>7</sup> / <sub>16</sub> "	9kgms	114gms/m 1.4oz/ft	5m (Europe) 20ft (US)
11RD (US only)	U01535 U01520Y	Rod	-	11mm <sup>7</sup> / <sub>16</sub> "	17kgms	211gms/m 2.1oz/ft	6m 20ft (US)
12R (Europe only)	U01535 U01520Y	Rod	-	12mm <sup>13</sup> / <sub>32</sub> "	17kgms	211gms/m 2.1oz/ft	6m (Europe) 19.7ft
14R	U01535	Rod	-	14mm <sup>9</sup> / <sub>16</sub> "	26kgms	286gms/m 3.07oz/ft	6m 19.7ft
16R	U01535	Rod	-	16mm <sup>5</sup> / <sub>8</sub> "	60kgms	364gms/m 3.92oz/ft	6m 19.7ft

20R also available. Please contact us for more details.

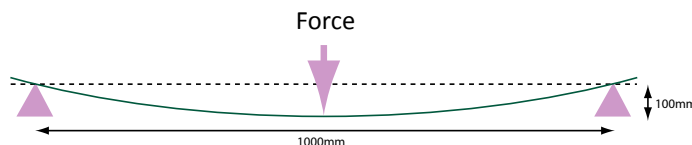

## Stiffness

Stiffness is calculated as the load needed to deflect a 1 metre length supported at both ends by 100mm.

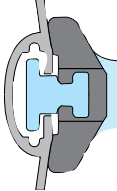

# Slide Selection Chart

Please note: Drawings are for illustration purposes only and are not actual size.

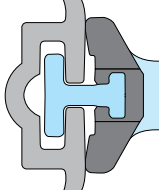
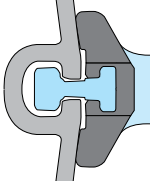
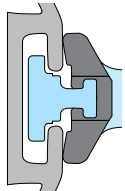
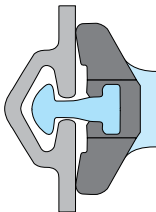
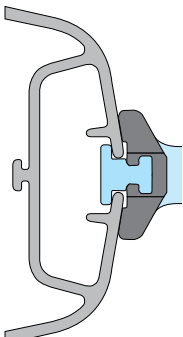
Part No.	Slide	Spar / Section Numbers
<b>U00462</b> Intermediate <b>U00442S</b> M10 <b>U00462H</b> 16mm headslide		NG 51, 46, 37, 31, 28 Z 300, 300E, 301, 400E, 404, 500E, 501
<b>U00468</b> Intermediate <b>U00448S</b> M10 <b>U00468H</b> 24mm headslide		For 25mm external mast track
<b>U00464</b> Intermediate <b>U00444S</b> M10 <b>U00464H</b> 19mm headslide		Kemp / Selden 'E' section F460, 305, 230, 135, 385
<b>U00472</b> Intermediate <b>U00452S</b> M10 <b>U00472H</b> 10mm headslide		Z380, 170, 190 PR 6140, 8946 ILC 46
<b>U00466</b> Intermediate <b>U00446S</b> M10 <b>U0446SHD</b> M10 <b>U00466H</b> 23mm headslide		NG86, 80, 70, 60, 105 Z600E, 700E, 800E, 900, 1100 F1395, 1060, 580, 740 PR 7651
<b>U00474</b> Intermediate <b>U00454S</b> M10 <b>U00454SHD</b> M10 <b>U00474H</b> 11mm headslide		Z531, 230, 265, 204, 480, 120, 160, 360, 145, 601, 701 PR 6645, 4529R PR10, PR12, PR6
<b>U00463</b> Intermediate <b>U00443S</b> M10 <b>U00463H</b> 19.8mm Heavy duty headslide Selden 'C'		Selden 'C'



# BAINBRIDGE

## INTERNATIONAL

### **Bainbridge International Ltd.**

8 Flanders Park  
Hedge End  
Southampton  
Hampshire  
SO30 2FZ  
**England**

Tel: +44 (0)1489 776010  
Fax: +44 (0)1489 776015

email: [info@bainbridgeint.co.uk](mailto:info@bainbridgeint.co.uk)

### **Bainbridge International Inc.**

255 Revere Street  
Canton  
Massachusetts  
02021  
**USA**

Tel: +1 781 821 2600  
Fax: +1 781 821 2609

email: [info@bainbridgeint.com](mailto:info@bainbridgeint.com)

### **Bainbridge International Inc.**

15242 Transistor Lane  
Huntington Beach  
California  
92649-1142  
**USA**

Tel: +1 714 373 3322  
Fax: +1 714 373 3326

email: [info@bainbridgeint.com](mailto:info@bainbridgeint.com)

### **Q.C.D Limited**

28 Hargreaves Street  
Ponsonby  
Auckland  
**New Zealand**

Tel: +64 (0) 9 366 7118  
Toll Free: +61 (0) 9 366 7119

email: [sales@qcd.co.nz](mailto:sales@qcd.co.nz)

### **Bainbridge International Pty. Ltd.**

273 Harbord Road  
PO Box 254  
Brookvale  
NSW 2100  
**Australia**

Tel: +61 (0)2 9938 1788  
Toll Free: +61 18 0073 1149  
Fax: +61 (0)2 9938 2459

email: [info@bainbridgeint.com.au](mailto:info@bainbridgeint.com.au)

### **Bainbridge International France**

UniSails SARL  
5 rue Marius Berliet  
PA de la Billais Deniaud  
44360 Vigneux de Bretagne  
**France**

Tel: +33 (0)2 51 13 05 40  
Fax: +33 (0)2 51 13 04 56

email: [info@bainbridgeint.fr](mailto:info@bainbridgeint.fr)

### **Asperö Handels AB**

PO Box 5009  
Traneredsvägen 112  
SE-426 05 V. Frölunda  
**Sweden / Norway**

Tel: +46 31 299 190  
Fax: +46 31 691 965

email: [info@aspero.se](mailto:info@aspero.se)

### **BB Technics Oy**

Sinikalliontie 18 B  
FIN-02630 Espoo  
**Finland**

Tel: +358 103 098 560  
Fax: +358 103 098 565

email: [info@bbtechnics.fi](mailto:info@bbtechnics.fi)

### **Fordewind-Regatta Ltd**

Petrovskaya Kosa 7  
197110 St. Petersburg  
**Russia**

Tel: +7 812 327 4580  
Fax: +7 812 327 4581

email: [alexey.rusetsky@fordewind.spb.ru](mailto:alexey.rusetsky@fordewind.spb.ru)

### **Columbus Marine A/S**

Svejsegangen 3  
DK-2690 Karlslunde  
**Denmark**

Tel: +45 4619 1166  
Fax: +45 4619 1353

email: [columbus@columbus-marine.dk](mailto:columbus@columbus-marine.dk)

### **Takis Kokkotas Co. Ltd.**

80 Mezonos Str  
104 38 Athens  
**Greece / Bulgaria / Romania**

Tel: +30 210 52 28 540  
+30 210 52 25 897  
Fax: +30 210 5247225

email: [info@kokkotas.gr](mailto:info@kokkotas.gr)

### **On Deck BV**

Leimuiderdijk 478a  
2156 MX Weteringbrug  
**Holland**

Tel: +31 (0)71 3313366  
Fax: +31 (0)71 3313387

email: [allhands@on-deck.nl](mailto:allhands@on-deck.nl)

### **Herman Gotthardt GmbH**

Leunastrasse 50  
D-22761 Hamburg  
**Germany**

Tel: +49 40 85150550  
Fax: +49 40 8509133

email: [info@gotthardt-yacht.de](mailto:info@gotthardt-yacht.de)

### **Boat Rigging s.r.l**

Via San Gallo 23  
Tavarnelle Val di Pesa Loc. Sambuca (FI)  
**Italy**

Tel: +39 055 8071964  
Fax: +39 055 8091541

email: [luca@boatrigging.it](mailto:luca@boatrigging.it)

### **Sacloma S.a.s**

Via Cisa Sud 125  
19037 S. Stefano di Magra (SP)  
**Italy**

Tel: +39 0187 630603  
Fax: +39 0187 633264

email: [sacloma@sacloma.com](mailto:sacloma@sacloma.com)

***Technical Innovation and Service - The Fabric of Our Business***